

Product Summary

Symbol	Value	Unit
$I_{T(RMS)}$	4.0	A
$V_{DRM} V_{RRM}$	600 / 800	V
I_{GT}	200	μA

Feature

With high ability to withstand the shock loading of large current, Provide high dv/dt rate with strong resistance to electromagnetic interference.

Application

Power charger, T-tools, massager, solid state relay, AC Motor speed regulation and so on.

Package

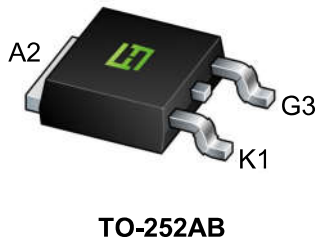

Circuit diagram

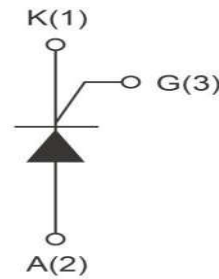

Absolute maximum ratings (Ta=25°C unless otherwise noted)

Parameter	Symbol	Value	Unit
Repetitive peak off-state voltage	V _{DRM}	600 / 800	V
Repetitive peak reverse voltage	V _{RRM}	600 / 800	V
RMS on-state current	I _{T(RMS)}	4	A
Non repetitive surge peak on-state current (full cycle, F=50Hz)	I _{TSM}	30	A
I ² t value for fusing (tp=10ms)	I ² t	4.5	A ² s
Critical rate of rise of on-state current (I _G = 2 × I _{GT})	di _T /dt	50	A/μs
Peak gate current	I _{GM}	1.2	A
Average gate power dissipation	P _{G(AV)}	0.2	W
Junction Temperature	T _J	-40 ~ +110	°C
Storage Temperature	T _{STG}	-40 ~ +150	°C

Electrical characteristics (T_A=25 °C, unless otherwise noted)

Parameter	Symbol	Test Condition	Value		Unit
			Min	Max	
Gate trigger current	I _{GT}	V _D = 12V R _L = 140Ω T _J = 25°C	10	200	μA
Gate trigger voltage	V _{GT}		-	0.8	V
Gate non-trigger voltage	V _{GD}	V _D = V _{DRM} R _{GK} = 1kΩ T _J = 110°C	0.2	-	V
latching current	I _L	I _G = 1mA R _{GK} = 1kΩ T _J = 25°C	-	6	mA
Holding current	I _H	I _T = 50mA R _{GK} = 1kΩ T _J = 25°C	-	5	mA
Critical-rate of rise of commutation voltage	dV _D /dt	V _D = 2/3V _{DRM} R _{GK} = 1kΩ T _J = 110°C	10	-	V/μs
STATIC CHARACTERISTICS					
Forward "on" voltage	V _{TM}	I _{TM} = 8A tp = 380μs	-	1.55	V
Repetitive Peak Off-State Current	I _{DRM}	V _D = V _{DRM} V _R = V _{RRM}	T _J = 25°C		μA
Repetitive Peak Reverse Current	I _{RRM}		T _J = 110°C		mA
THERMAL RESISTANCES					
Thermal resistance	R _{th(j-c)}	Junction to case (AC)	TYP.	7.2	°C/W
	R _{th(j-a)}	Junction to ambient	TYP.	100	°C/W

Typical Characteristics

FIG.1: Maximum power dissipation versus RMS on-state current (full cycle)

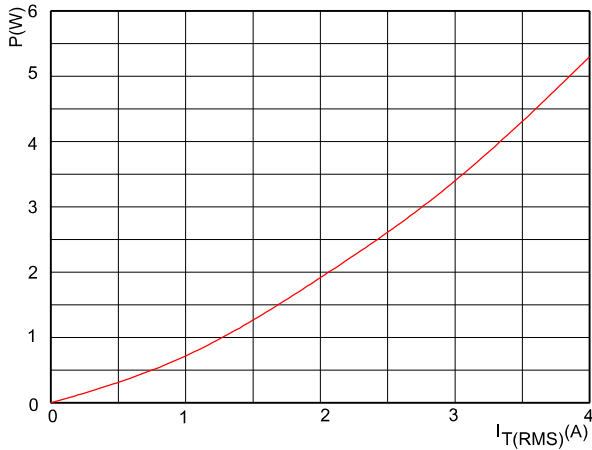

FIG.2: RMS on-state current versus case temperature (full cycle)

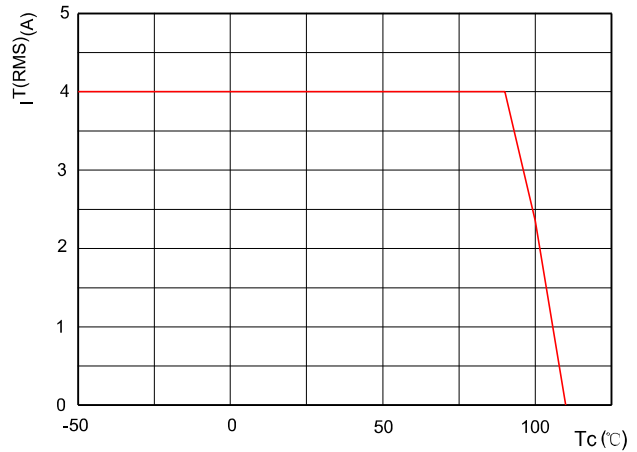

FIG.3: Surge peak on-state current versus number of cycles

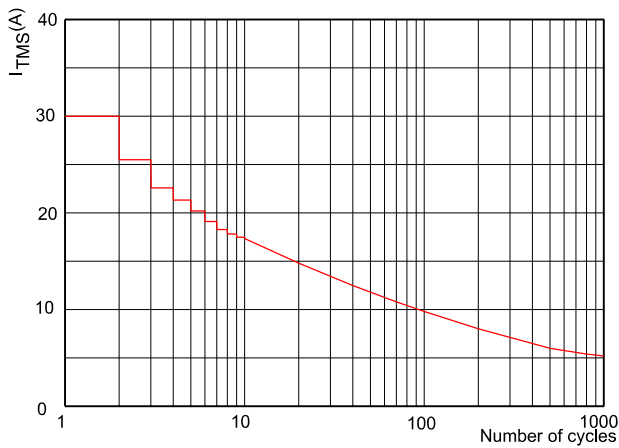

FIG.4: On-state characteristics (maximum values)

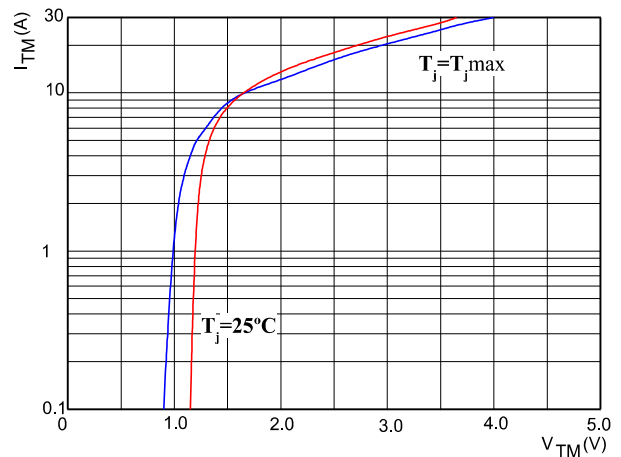

FIG.5: Non-repetitive surge peak on-state current for a sinusoidal pulse with width $t_p < 10\text{ms}$

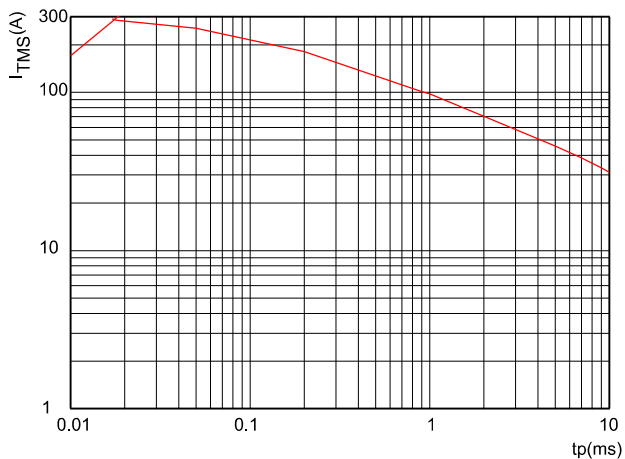
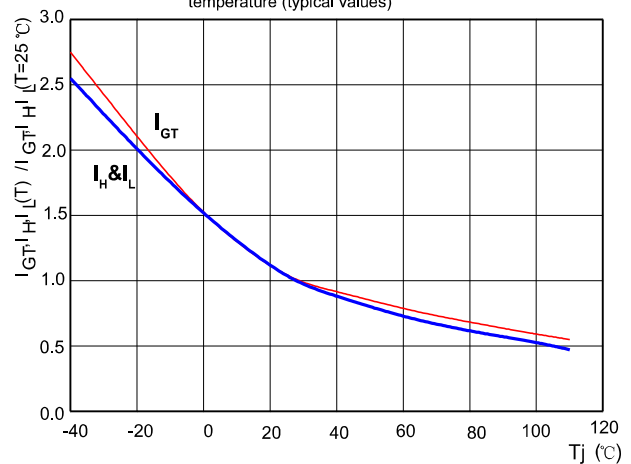
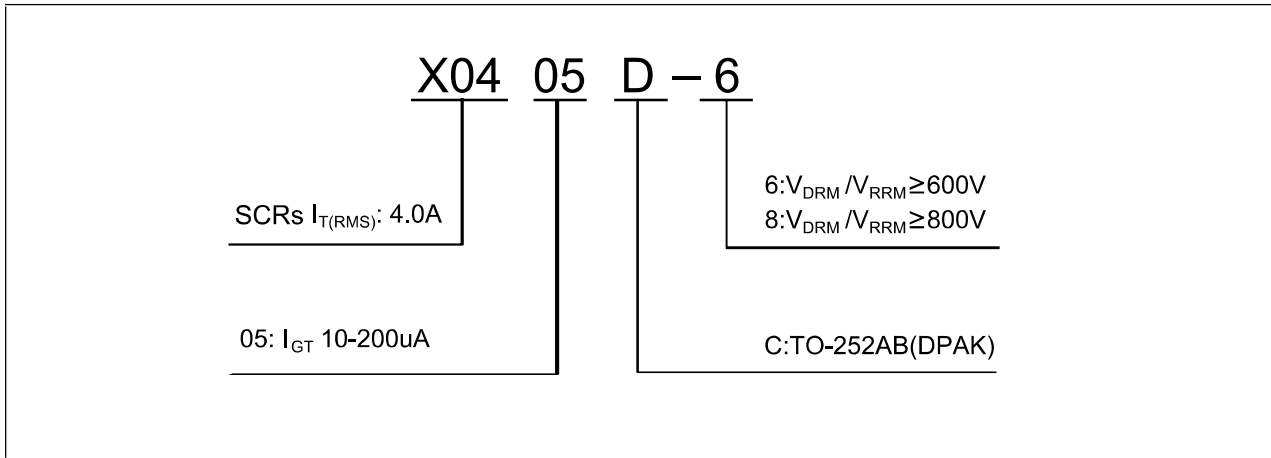

FIG.6: Relative variations of gate trigger current, holding current and latching current versus junction temperature (typical values)



Ordering Information



TO-252AB Package Information

